



1 Fair Skies Drive Ona, WV 25545 Tel: 954-881-4271 Fax: 954-771-9809 email: lynnz@onaairpark.com

2020 OPEN WHEEL MODIFIED RULES

February 7, 2020

ONA SPEEDWAY 2020 MODIFIED RULES

Note: Sanctioning body and/or track does not express or implies any warranty of safety resulting from the publication of or compliance with these rules and/or regulations. These rules are intended as a guide to conduct this sport and are not in any way a guarantee against injury or death to any participant, spectator or official.

1. **SAFETY EQUIPMENT:** Snell-rated SA2005 helmet required. Roll bar padding required in drivers compartment (fire retardant highly recommended). SFI full fire suit required. Fire retardant neck brace, gloves and shoes required. (Fire retardant head sock and underwear, head and neck restraints; collapsible steering shaft; highly recommended). Driver side window net required, and must be mounted so that the latch is at the top front of window. Minimum three inch wide, five point safety belt assembly required, must be mounted securely to the role cage. (Highly recommended to be no more the 3 years old). Fire extinguisher is required. (A separate, heat activated, fire bottle on the fuel cell is highly recommended). Kill switch required within easy reach of driver and must be marked 'OFF' and 'ON'.
2. **FRAME:** 1964 or newer OEM perimeter American made rear wheel drive passenger car frame only. (Reproduction 68-72 Chevelle frames are approved). No sports car frames. No 2002 & up Ford Crown Vic or similar frames allowed. No strut front suspension of any kind allowed. No tube clips allowed. Frame must be full and complete, cannot be widened or narrowed, and must be able to support roll cage on both sides. **EXCEPTIONS:** Weight jack in original center line of spring tower; frame may be cut a maximum 36 inches forward from center of rear housing; horns may be removed in front of steering box; front crossmember may be notched and boxed for radiator and/or steering clearance; maximum 7 inch wide opening in side of spring tower for spring removal. OEM upper A mounts may be replaced with aftermarket mounts. Maximum 4 inch wide by 4 inch tall frame stiffener may be welded directly to outside of left OEM frame rail. Left side OEM frame rail may be notched for seat and foot clearance. Minimum wheelbase 108 inches, maximum 112 inches, both sides. Maximum overall width, front and rear, shall not exceed 78 inches of tread patch. No part of frame or body shall be lower than 4 inches from ground, except the front crossmember, in race trim.
3. **ROLL CAGE:** Must consist of continuous hoops, minimum 1.75 inch O.D. tubing, with a minimum wall thickness of .095 inch for the main cage. Frame mounted in at least 6 places, low carbon or mild steel recommended. Must consist of a configuration of front, rear, and top hoops connected by tubing on the sides or side hoops. Drivers head must not protrude outsidecage with helmet on. Roll cage must be securely supported and braced with minimum 1 cross bar in top halo. Foot protection bar(s) required. Main cage no further forward than rear of engine. All bars forward of the cage must be lower than the hood.



2020 OPEN WHEEL MODIFIED RULES

February 7, 2020

Page 2 of 6

4. **DOOR BARS:** All driver side door bars and uprights must be a minimum 1.75 inch and .095 inch wall thickness. Minimum 4 driver side door bars, parallel to the ground and perpendicular to the driver, and welded to the front and rear roll cage. Passenger side must have at least 1 cross door bar, horizontal or angled, and 1 top door bar, minimum 1.5 inch O.D. steel door plate, 16 gauge (.065) minimum thickness, must be securely welded to outside of the driver side door bars and cover the area from top door bar to bottom door bar and from rear hoop down post to front cage down post.
5. **BODY:** (SEE DIAGRAM) must be same width, front to rear, and parallel to the OEM frame. Engine compartment must remain open on both sides. Hood must be enclosed at rear. No panel in front of right door to engine compartment. No inner panels. Must have front windshield support and rear window support posts. Driver and passenger side windows must have at least 12 inch opening (height & width), measured at enter of window, between lowest point at top of window, weather roof or roll cage, and the highest point at bottom of window, weather interior or body. May use Lexan in sail panels. **ROOFS ARE OPTIONAL.** (If car has no roof, driver must wear arm restraints) Roofs must be fiberglass or aluminum (no carbon fiber) full size, rounded and stock appearing (no flat roofs). Must run full upper and lower nose. No wings or aero dynamic devices inside or outside the car. Outside of tires must be the widest part of car. Quarter panels and B/C pillars must be 2 distinct pieces. Oil coolers/radiator must not protrude above interior or outside of body. (Spoiler:) A 4 inch by 66 inch spoiler. The wicker on the spoiler must go to the back NOT the front.
6. **DRIVER COMPARTMENT:** Must have a minimum 3 windshield bars in front of the driver. Lexan or aluminum cowl panel in front of the driver can be no wider than the cockpit and no farther back than the steering wheel. Minimum .125 inch aluminum, or 22 (.035 inch) gauge steel, complete floor pan required. Aluminum high back seat only and must be bolted in securely, inside the left OEM frame and ahead of the rear tires. Bottom of seat can be no lower than bottom of frame. (NASCAR style right and left head, shoulder supports and let restraints highly recommended). Driver must be sealed off from track, driveline, engine, fuel cell, battery and pumps. No driver adjustable devices allowed in cockpit except brake adjusters.
7. **FRONT SUSPENSION:** All components must be steel, unaltered OEM, in OEM location, and replaceable by OEM parts. No aluminum hubs. **EXCEPTIONS:** Tube type upper A frames with or without aluminum or steel cross shaft, and mounts can be moved; radius rod tubes may be steel or aluminum. stamped steel OEM replacement lower A frames; rubber, nylon, or steel lower A frame bushings; no offset bushings; welded or bolted shock mounts on lower A frames; (No fabricated lower A frames); Lower A frames must be right and left and of the same design. Lower A frame mounts and bolt holes on frame must be in OEM location no modifications and no adjustments on lower A frames or frame mounts **AT ALL**, OEM type ball joints only. Sway bar must be OEM type, no splined bars. Bump stops may be used.



2020 OPEN WHEEL MODIFIED RULES

February 7, 2020

Page 3 of 6

8. **STEERING:** No rack and pinion. All components must be steel, unaltered OEM, in OEM location. **EXCEPTIONS:** tie rod ends and adjuster sleeves may be replaced by a minimum .625 inch steel rod ends and steel tubes; OEM spindles can be modified for ball joints and tie rod ends; passenger car drop spindles allowed; (No made for racing or fabricated spindles.) Spindle saver allowed; spindles must be right and left, and of the same design; steel steering shafts and knuckles only; steering quickener, steering wheel and quick release may be aluminum; driver compartment steering may be modified, but must be kept on left side. OEM center link or OEM after market type center links allowed.
9. **SHOCKS:** Shocks must be, non-adjustable, with No external canisters, and have a racer price of less than \$350.00 New per shock. 1 shock per wheel. 1 additional shock allowed in the lift/pull bar area. No air shocks. No adjustable rebound shocks allowed.
10. **SPRINGS:** Steel coil and leaf springs allowed. Coil springs must be at least 4.5 inches O.D. No torsion bars or air bags. **EXCEPTION:** Pull bar may utilize smaller O.D. springs.
11. **REAR SUSPENSION:** No independent rear suspension. All components must be steel. No covers allowed. All trailing arms/link bars must be made of steel tubing. Rear of frame may be altered to accept leaf or coil springs. Steel coil-over eliminators, and steel or aluminum (5") coil-over kits allowed on the rear only. Must conform to shock and spring rules. One (1) mechanical traction bar only. No rear sway bars. Aluminum panard bar adjuster allowed. Steele 2-piece aftermarket rotors permitted on all 4 hubs.
12. **REAR END:** Any steel approved OEM passenger car or truck rear end allowed. Steel tube Quick change allowed. Safety hubs (floater) mandatory. Steel axles only. No cambered rear ends. One (1) piece drive flange only. All components must be steel. **EXCEPTION:** lowering blocks, axle caps, rotor plates, and drive flanges.
13. **BUMPERS:** (See diagram) Steel bumpers must be on front and rear at all times and welded or bolted securely to the frame. Must be a minimum 1.25 inch O.D. tubing, .065 wall thickness. Two bar front bumper must be mounted frame end to frame end, no wider than with of OEM frame horns. Bottom loop must be parallel to the ground. Top bar must be directly above bottom bar, minimum 6.5 inches apart, measured center to center. Aluminum I-beam rear bumper are allowed. **NO SHARP EDGES.**
14. **WHEELS:** Eight (8) inch steel wheel only, measured from inside bead to inside bead. No bead locks, screws, or rim mounted bleeder valves. Steel and aluminum wheel spacers are allowed.



2020 OPEN WHEEL MODIFIED RULES

February 7, 2020

Page 4 of 6

15. **TIRES:** No softening, soaking, conditioning, siping, or grooving of tires. No re-caps. **SOAKING OF TIRES IS STRICTLY PROHIBITED.** (This rule applies to ALL tires in the pits, on the car, in the trailer or hauler, ALL tires). Tires may be checked at any time. American Racer 970 is only tire allowed. All race tires must have baby powder in them. After feature official will have you break down 1 or 2 to check for powder. top 3 in feature.
16. **BRAKES:** Must be steel OEM type, operative on all 4 wheels, drum or disc. Must maintain minimum OEM dimensions for hub/rotor and calipers, cannot be drilled or lightened. Bolt pattern may be changed. Larger studs allowed. Rear rotors may be aftermarket, minimum .810" thick, vented rotors only. **NO** scalloped or drilled rotors. steel 2-piece aftermarket rotors permitted on all 4 hubs.
17. **EXHAUST:** Round tube headers only. All primary tubes must enter into 1 collector, at the end of the header.
18. **FUEL SYSTEM:** Mechanical or belt driven pump only and must be mounted on front of motor. Racing fuel cell required 22-gallon maximum capacity, square or rectangle in shape (no tear drop, wedge, or exotic F-1 type fuel cells allowed). Must be in a minimum 22-gauge steel container. Cell must be securely mounted behind the rear axles and between the rear tires. Cell must be no lower than bottom of rear end housing. Cell must be mounted with a minimum 2 solid steel strap around the entire cell, 2 inches wide and .125 inches thick or equivalent. All cell mounts must be steel and securely welded past both ends of the cell. No part of the cell is to be lower than the protective tubing. Vents and lids must have check valves. Fuel line pick up must be on top to cell. No cool cans and (1) fuel filter only.
19. **FUEL:** Racing gasoline or alcohol allowed.
20. **WEIGHT:** Minimum weight limit of 2,400 pounds, 1000 pounds right side or 58% left side. (NO tolerance), after race with driver and helmet in car sitting in normal driving position. Weights must be securely mounted with at least (2) half inch bolts to frame or roll cage and painted white with car number on it. No weight outside of the body. No titanium, carbon fiber, or exotic materials used on race car. No gun-drilled, tubular, hollow bolts or studs. Steel fasteners only.
21. **BATTERY/STARTER:** One 12/16 volt battery only, must be securely mounted between frame rails, behind crossmember, in front of rear end and outside of driver cockpit, with positive terminal covered. Car must have the capacity of starting without being pushed or pulled. Standard or reverse mount starters allowed.
22. **GAUGES/ELECTRONICS:** No electronic monitoring computer devices capable of storing or transmitting information. **EXCEPTION:** Analog tach. No adjustable ignition control boxes. One (1) 12- or 16-volt ignition box allowed, with rev chip, must be out of reach of the driver. No additional ignition accessories allowed. No magnetos. No traction control devices of any kind, **IF FOUND ON CAR WILL RESULT IN LOSS OF ALL POINTS FOR SEASON AND DQ.**



2020 OPEN WHEEL MODIFIED RULES

February 7, 2020

Page 5 of 6

23. **TRANSMISSION:** Must have at least two forward gears and one reverse, plus a neutral position. With engine running and car in still position, must be able to engage car in gear and move forward, then backward. OEM production type or approved aftermarket transmissions (Bert, Brinn, Falcon allowed. 2-speed, 3-speed 4-speed and automatic). No 5-speeds or more transmissions, No 'in and 'out boxes allowed. Standard clutch type transmissions must have a blow proof bell housing (steel or aluminum). Automatic transmissions must have an approved scatter shield.
24. **DRIVE SHAFT:** Minimum 2.5 inch diameter, steel drive shaft, painted white. Steel slip-yokes only. 360 degree drive shaft loop required and must be constructed of at least .25 inch by 2 inch steel or equivalent, mounted 6 inches back from front u-joint.
25. **ENGINE COMPARTMENT:** Rear of engine must be mounted at least 72 inches forward from centerline of rear axle. Engine offset must be kept within 2 inches of centerline of front crossmember with engine level. Minimum 11 inches from centerline of crank shaft to ground. Radiator must be mounted in front of engine. Cooling system may be modified. No anti-freeze.
26. **ENGINE:** Any American make engine allowed. Steel block. No machine work on the outside of block (lightening). Wet sump oiling system only. One (1) naturally aspirated two or four barrel carburetor only. NO fuel injection No magnetos.
27. **NUMBERS / DECALS:** All numbers shall be in contrasting color from body, affixed to both doors and top, be at least 4 inches thick and 20 inches tall, and be readable from the passenger side of car.
28. **OVERALL:** (A) Track reserves the right to change, modify, add or delete to these rules as they deem necessary to ensure fair, competitive, and affordable racing. (B) Track reserves the right to confiscate any part or parts deemed by their Officials to be outside the rules. This to include tires, or any part(s) of any race car, at any event, at any time. (C) All decisions of the Officials are final and binding without exception.
29. **GENERAL COMPETITION:** (A) Drivers shall be responsible for the conduct and actions of all crew members, and any unsportsmanlike conduct shall be grounds for disqualification or punitive action as determined by Sanctioning body and/or track. Sanctioning body and/or track shall have the authority to disqualify members and assess fines. (B) All discussions with Officials shall be conducted in a professional manner and at a proper distance. (C) Drivers under the age of 18 must produce a signed parental consent form by parent or legal guardian. (D) Sanctioning body and/or track may require, at its option, a competitor(s) to undergo a physical or drug testing before said individual(s) are allowed to compete.
30. **MIRRORS** are allowed **NO TWO-WAY RADIOS, NO EXCEPTIONS.** All cars must have Receiver on 454.0000 **THE ABSENCE OF A PARTICULAR RULE DOES NOT NECESSARILY MEAN ITS APPROVAL!**



AIRPARK & SPEEDWAY

2020 OPEN WHEEL MODIFIED RULES

February 7, 2020

Page 6 of 6

ASPHALT BODY DIAGRAM & DIMENSIONS

A - 20" MAX. – 16" MIN. (GROUND TO CENTER OF BUMPER FRONT & REAR)

B - 605" MIN. (CENTER TO CENTER)

C - 46" MAX. – 42" MIN.

D - 6" MAX. HOOD SIDES – 3" MAX. RAKE IN HOOD

E - 32" MAX. (BUMPER & NOSE)

F - 6" MAX. (SCOOP/DEFLECTOR)

G - 4" MIN. AT NOSE AND SIDES – 8" MIN. AT QUARTERS

H - 19" MAX. (SAME BOTH SIDES)

I - 112" MAX. – 108" MIN.

J - 29" MAX. – 22" MIN

K - 72" MAX. OR NOT PAST BACK OF BLOCK, RIGHT SIDE. LEFT SIDE MAY EXTEND FORWARD TO COVER FOOT BOX IF NECESSARY.

L - 18" MAX. – 12" MIN. OPENING, BOTH SIDES.

M - WITH 4' LEVEL, MUST HAVE 2" GRADUAL CLEARANCE AT REAR AND NO MORE THAN 5" AT FRONT

N - 120" MAX. – 106" MIN. O. 45" MAX. – 34" MIN.

P - 3" MAX. HEIGHT AT REAR OF SAIL PANEL, GRADUAL SLOPE FROM ROOF TO THIS POINT. (4" X 66" MAX)

Q - INTERIOR SLOPE IS 6" MAXIMUM. FRONT TO REAR AND FLAT ACROSS. IF FLAT AT FRONT HALF OF INTERIOR YOU HAVE USED UP 50% OF YOUR 6" SO FROM BEHIND THE DRIVER TO THE REAR YOU ONLY HAVE 3" OF SLOPE. TOP OF INTERIOR MUST BE FLUSH WITH TOP OF DOORS AND QUARTER PANELS.

R - 38" Max - 28" Min

S - 38" Max- 24" Min

T - 66" Max - 24"Min NO NARROWER THAN RADIATOR

U - 52" Max - 44" Min

V - 56" Max - 41" Min W. TIRES MUST BE THE WIDEST PART OF THE CAR. MUST BE ABLE TO SEE SIDE WALL OF TIRE FROM FRONT, TOP AND REAR

X - 66" Max - 53" MIN

Y - 8" PANEL/90 DEGREES TO GROUND MUST BE SOLID, ATTACHED TO THE DECK AND EXTEND TO THE QUARTER PANELS, SECURELY FASTENED.

Z - ALUMINUM "I" BEAM OR TUBULAR STEEL REAR BUMPERS ALLOWED, MUST HAVE ROUNDED NERF BARS THAT FOLLOW QUARTER PANEL AND CONNECT BACK TO FRAME ON BOTH SIDES.

Modified Car Dimension Diagram on next page:

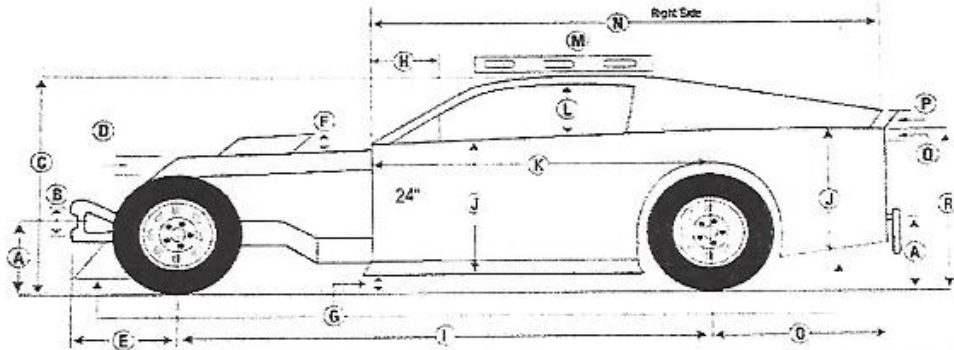

Shaded area reserved for Series and/or Track Sponsor Decals. MUST DISPLAY DECALS TO BE ELIGIBLE FOR FULL PURSE.

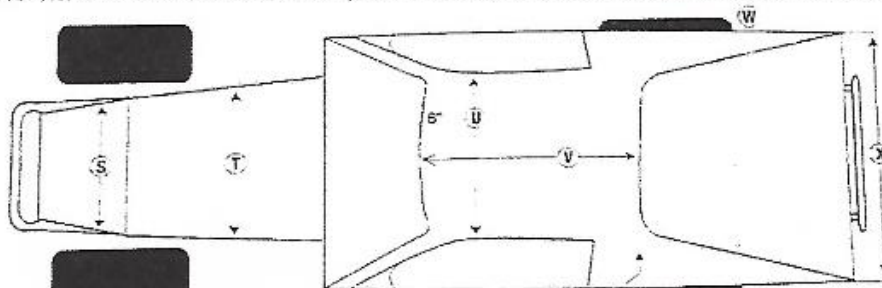

SAIL PANELS: Must not be wider than the body and must attach to the quarters in a single stock appearing plane that angles inward to the roof. No fins or lips on sail panels, body, or nose.

